

PRECAST ENABLES TOTAL ENVIRONMENTAL AVOIDANCE

by Ahmad Abdel-Karim, Thomas Barnard, and Orin Brown, DMJM Harris | AECOM

The constructed bridge provides a durable, low-maintenance solution that blends well with its surroundings

Daggett Road provides the link between California State Highway 4 and Rough and Ready Island, a former U.S. Navy facility that was recently decommissioned and turned over to the Port of Stockton, California. The new structure replaces an old steel truss swing-span bridge over Burns Cut-off with a four-lane precast concrete spliced girder bridge.

The Daggett Road Bridge consists of a three-span, spliced bulb-tee girder bridge with post-tensioned integral bent caps. Each girder line consists of three segments: two over the piers/end-spans and one middle drop-in segment. The 100-ft-long middle span drop-

in segments had to be installed from cranes operating on top of the partially completed deck over the end spans. Both the framing plan and the erection scheme were necessary to avoid working in the channel.

The unusual erection scheme produced some design challenges that had to be addressed. Most of these issues were related to the critical bending moment at the face of the bent cap. The combination of pretensioning and post-tensioning chosen to satisfy the stress limits resulted in exceeding the maximum reinforcement limit. This was overcome using a combination of design changes and analysis techniques.

profile

DAGGETT ROAD BRIDGE / STOCKTON, CALIFORNIA

ENGINEER: DMJM Harris | AECOM, Sacramento, Calif.

PRIME CONTRACTOR: Shasta Construction Inc., Redding, Calif.

PRECASTER: Con-Fab California Corporation, Lathrop, Calif., a PCI-Certified Producer

POST-TENSIONING CONTRACTOR: AVAR Construction Systems Inc., Campbell, Calif.

The new bridge provides a durable low-maintenance solution that blends well with its surroundings.
Photo: DMJM Harris.



Daggett Road links State Highway 4 with Rough and Ready Island.
Photo: DMJM Harris.

Alternative Designs

The site constraints precluded many standard bridge types from consideration, and left precast, prestressed concrete and structural steel as the only viable alternatives. The two candidates were approximately equal in the initial estimate of construction cost; however, the estimates did not consider the significant difference in structure depth between the two and its impact on the approach roadway embankment quantities. The single-span steel alternate would have been, at a minimum, 2.5 to 4.5 ft deeper than the minimum precast, prestressed concrete bulb-tee system. This would

have resulted in significant extension of the conform points, both on and off the island. Furthermore, the use of structural steel for bridge construction in California is not as common as either reinforced or prestressed concrete, and therefore comes at a premium price.

As a result, the preferred alternative consisted of a three-span, field-spliced, precast, prestressed concrete bulb-tee girder bridge. The system was the least intrusive to the sensitive environmental areas, provided reduced structure depth, facilitated more flexibility for the incorporation of aesthetics, and reduced approach roadway costs associated with the structure depth. Precasting the girders in short segments, then splicing them using post-tensioning tendons after placement, permitted the design to take advantage of the efficiency of a continuous structure without the need for extensive falsework in and around the waterway. Even with all the versatility and adaptability offered by the selected precast girder system, a special erection scheme was necessary to stay out of the channel and above the high water elevation.

Strongbacks were used to support the drop-in segments.
Photo: Port of Stockton.

Eight lines of spliced bulb-tee girders were used. Illustration: DMJM Harris.

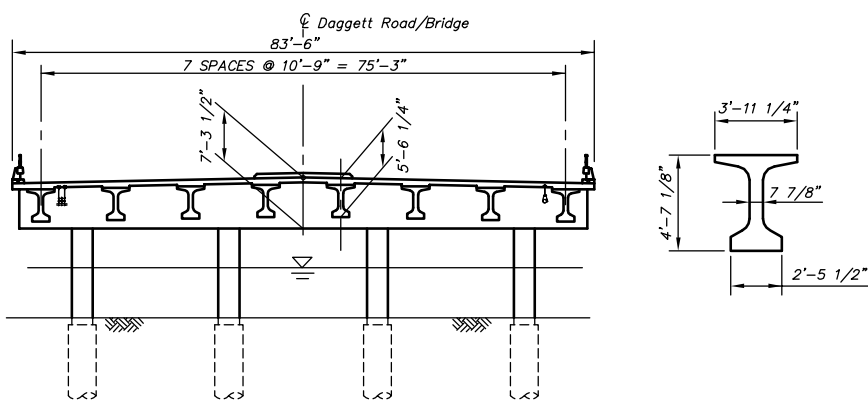

PRECAST, PRESTRESSED SPLICED GIRDER / PORT OF STOCKTON, CALIF., OWNER

BRIDGE DESCRIPTION: Three-span, spliced bulb-tee girder bridge with integral bent caps

STRUCTURAL COMPONENTS: Eight lines of spliced bulb-tee girders; cast-in-place, post-tensioned integral bent caps; cast-in-place deck slab; and cast-in-drilled hole piles

BRIDGE CONSTRUCTION COST: \$150/sq ft

Bridge Superstructure

The system utilizes field splices in the middle span, thus enabling the girder segments to be shipped in reasonable lengths. The splices were located near the span inflection points, which resulted in nearly equal drop-in and pier segment lengths. The superstructure of this bridge system consists of three main components: the end span/pier segments, the middle span drop-in segments, and the cast-in-place integral bents; these components are described below.

The end span/pier segments comprised prismatic bulb-tee girders that span between each abutment and the nearest bent, and cantilever nearly 24 ft into the middle span. The girders are pretensioned for shipping and handling stresses. The pretensioning strands are all straight and are located in the bottom flange of the girder, clear of the web area that houses the post-tensioning ducts. The pier segments also contain ducts for two stages of longitudinal post-tensioning: one for the girder-only section and one for girder-deck composite section.

The middle span drop-in segments span between the cantilever ends of the end



The integral post-tensioned bent caps transferred longitudinal moment between the columns and the superstructure. Photo: Con-Fab.



Cranes on the pier segments were used to erect the drop-in segments. Photo: Port of Stockton.

span/pier segments. They also consist of a constant depth bulb-tee shape for the positive moment region. They are pretensioned for lifting and handling stresses and contain ducts for the two-stage post-tensioning of the continuous girder and composite sections.

The cast-in-place integral bent system provides the connection of the precast pier segment to the columns. Each bent is a four-column, rigid frame supported on large diameter cast-in-drilled hole piles. The integral cap is formed and cast around and under the end span/pier segments, and stressed before the drop-in segments are erected, using transverse post-tensioning ducts passing through the end span/pier segments. Conventional reinforcement in the top slab and in the cap below the girders further improves the monolithic response of the integral connection. The resulting joint is capable of transferring longitudinal moment between the columns and the

superstructure through torsion and shear-friction at the bent cap/girder interface.

A critical feature of the integral cap system that contributed in no small part to the success of this project is that it enabled the elimination of temporary shoring supports under the girder splices. This is possible due to the inherent stability of the end span/pier segments after being rigidly connected to the columns and the subsequent casting of the deck before the drop-in segments are erected.

Construction Scheme

The key step in the construction sequence corresponds to the erection of the middle span drop-in segment (Step #3 in the sequence). This was necessary to avoid setting the cranes up on the levees or behind the abutments, where their carrying capacity would have been significantly reduced. Setting up and operating the cranes on the partially completed deck provided the logical solution.

Protecting the Environment

The project's environmental constraints played a key role in determining the type of bridge used. The project's funding was tied to a "sunset clause" with a fixed expiration date. In order to meet the funding deadline set by this agreement, it was necessary to accelerate the project by adopting a "total avoidance" strategy. As implied by the name, the alignment avoided impacts

to sensitive resources and their habitats, thus reducing permitting processes from formidable to programmatic for most of the regulatory agencies involved. However, as a result of this strategy, no work could be performed in the channel below the ordinary high-water (OHW) elevation at any time during construction. These constraints precluded many standard bridge types from

consideration, and left precast concrete as the only economically viable alternative. Even with all the versatility and adaptability offered by the selected precast girder system, a special erection scheme was necessary to stay out of the channel and above the specified OHW elevation. The constructed bridge provides a durable, low maintenance solution that blends well with its surroundings.

Construction sequence. Illustration: DMJM Harris.

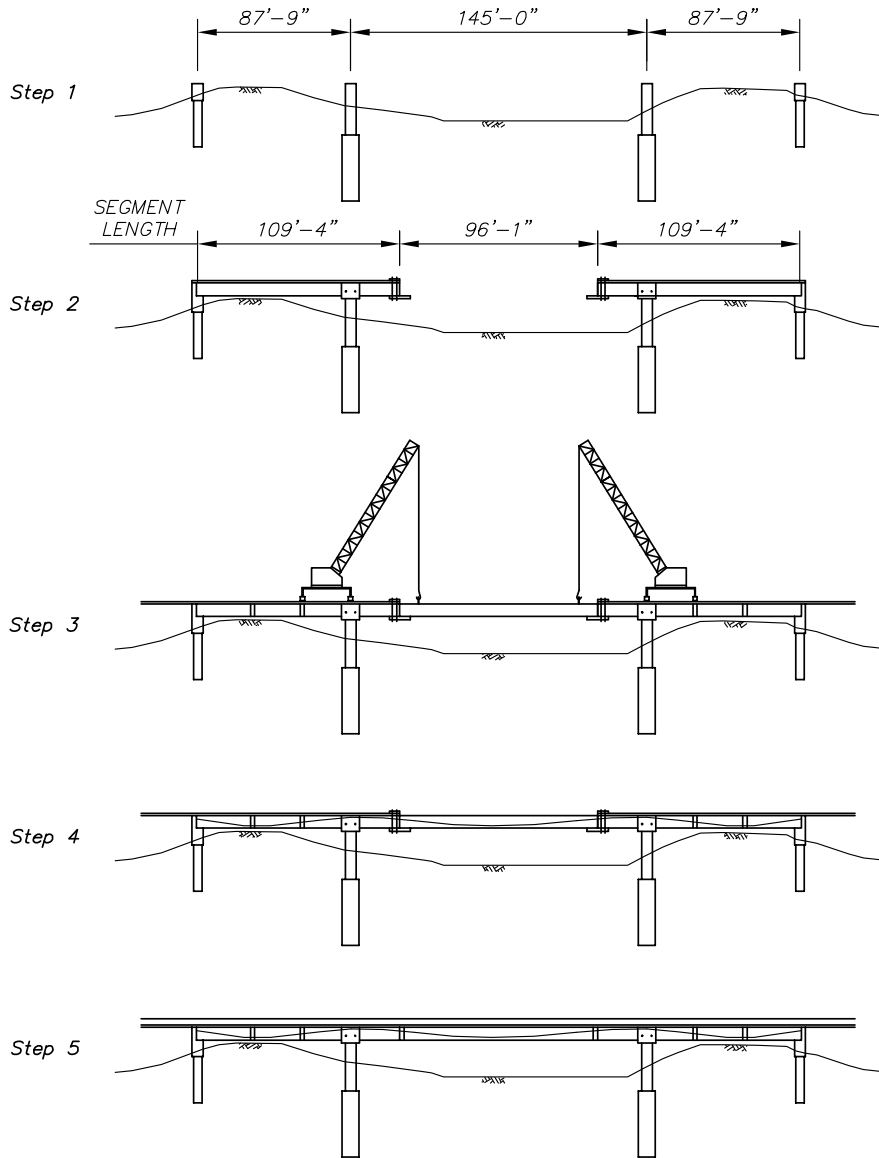

However, extensive analysis and verification was necessary to ensure that this solution was structurally viable and safe. Consultation with the precasters and crane companies yielded information about the crane's required capacity and the magnitude of its maximum anticipated reactions. This information was then used to delineate the physical limits of the permissible crane operations that did not violate the girders' temporary stress limits.

The project plans and specifications provided adequate detail to the contractor to devise an erection scheme within these limits. As an example, the plans required that intermediate diaphragms be centered under the crane outrigger pads, as determined by the contractor. This

requirement was there to protect the deck slab and distribute the crane rear outrigger loads evenly among the girders. The design plans provided a variable dimension to locate the intermediate diaphragm, since the dimensions of the crane were unknown at the time of design. This process proved to be effective in avoiding potential problems and construction went exceptionally well.

Ahmad Abdel-Karim is Associate Vice President, Thomas Barnard is Vice President, and Orin Brown is Senior Bridge Engineer with DMJM Harris | AECOM, Sacramento, California.

For more information on this or other projects, visit www.aspirebridge.org.



AESTHETICS COMMENTARY

by Frederick Gottemoeller

For many precast concrete girder bridges, particularly low ones, the biggest aesthetic problem is often the size and shape of the pier caps. They can break up the horizontal lines of the bridge, creating a visual stop at each pier line. On very low bridges, they can look like a series of transverse walls segmenting the space under the bridge. The Daggett Road Bridge avoids these potential problems. Driven by the necessities of the site, the designers have come up with innovative techniques to raise the pier caps into the plane of the girders. The method also creates structural continuity across the piers, allowing the girders to be shallower than usual. Shallowness is especially appreciated in a structure that is low to the water like this one. The result is a graceful, well-proportioned structure that sweeps cleanly from bank to bank while leaving a significant opening below.

There is a tendency to downplay the appearance of small, out of the way bridges, like the Daggett Road Bridge. However, almost all bridges are important features in somebody's neighborhood or somebody's park. They all deserve attention to their appearance. Our goal should be to achieve efficiency, economy, and elegance on every structure. The structural innovations used in this structure would benefit the appearance of other precast concrete girder bridges, as well as create functional advantages such as longer spans. They should be considered wherever precast girders are being designed.

The preferred alternative consisted of a three-span, field-spliced, precast, prestressed concrete bulb-tee girder bridge.



Cranes on the pier segments were used to erect the drop-in segments. Photos: Port of Stockton



Temporary supports were provided at the bent caps to support the pier segment.
Photos: Con-Fab.